

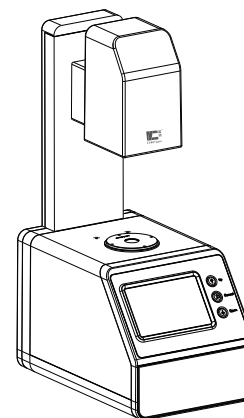

领先的中国色彩与光泽分析专家
China's leading expert of color and gloss analysis



雾度计 产品使用说明 ▶ TH-100



杭州彩谱科技有限公司
HANGZHOU CHNSPEC TECHNOLOGY CO.,LTD

地址：杭州市江干区文渊北路166号华银教育大厦7楼

全国免费电话：4007-7272-81

传真：0571-85888727

CATALOGUE

目录

[一] 雾度计使用须知	01
[二] 雾度计注意事项	01
[三] 雾度计功能描述	02
[四] 雾度计技术参数	02
[五] 外观结构介绍	03
[六] 测量流程图	04
[七] 程序界面介绍	04
[八] 测量	05
8.1 标样测量	05
8.2 试样测量	06
[九] 数据查看	06
[十] 设置	08
10.1 测量设置	08
10.2 系统设置	12
10.3 校准	15
[十一] USB通信	15
[十二] 参数介绍	16
[十三] 异常处理分析	17
[十四] 附件	17
[十五] 公司声明	18

雾度计使用须知

- 1、雾度计是一台设计用于测定塑料、薄膜、玻璃制品、LCD面板等透明、半透明平行平面材料的雾度、总透光率的仪器。
- 2、雾度计广泛应用于实验室、工厂、或现场操作，足以在几乎所有应用领域的质量控制中实现准确的雾度测量。
- 3、限制性保修的时间段是自购买本仪器开始起（时间：如一年）的时间。如果您的仪器需要服务，请将仪器带到当地的销售部或通过网址：www.hzcaipu.com 联系我们来进行维修。
- 4、为了避免仪器精度受影响，请不要将仪器私自拆开。如果由于私自拆卸机器或不正确的使用而导致仪器损坏，请用户自行负责。

雾度计注意事项

- 1、本机属精密仪器，不能承受跌落导致的碰撞，使用时请放置于相对平整的地方。
- 2、本机不能防潮或抗潮，受潮或液体溅入易损坏本机。
- 3、本机的屏幕是由玻璃制成，受到异常外力或锐器的作用易损坏。
- 4、本公司建议使用原配电源适配器。
- 5、为保障本机正常工作，请不要在过冷或过热的地方存贮和使用，也勿将本机放置在潮湿或阳光长期直射的地方，更不要在强震等恶劣的环境中使用本机，以免发生意外。
- 6、本机是精密仪器，使用时请避开强电磁干扰。
- 7、为保证测量准确，测试时请保持仪器平稳，不要摇晃。
- 8、本机属精密仪器，使用完毕请将仪器关机保管。
- 9、请将仪器存放在干燥的地方。
- 10、禁止对积分球内部进行清洁。
- 11、如果仪器发生故障，请不要尝试自行修理，我们的客户服务部门会快速的为客户提供帮助。
- 12、本机及说明书如有进一步改进或补充，恕不另行通知。如有疑问，敬请垂询本公司。

雾度计功能描述

- 1、雾度计符合以下测试标准：ASTM D1003/D1044,ISO 13468/ISO 14782,JIS K 7105,JIS K 7361,JIS K 7136,GB/T 2410-2008。
- 2、雾度计满足CIE-A、CIE-C、CIE-D65三种标准照明光源下的雾度与全透射率测量。
- 3、雾度计满足补偿法测试，可提供更准确的测试结果。
- 4、雾度计拥有开放式的测量区域，可以满足任意大小的样品测量。
- 5、雾度计采用5.0寸TFT显示屏，拥有良好的人机交互界面。
- 6、雾度计提供专业的雾度以及透射率的测量分析软件，可以满足用户对测试数据的分析以及管理。

技术参数

光源	CIE-A,CIE-C,CIE-D65
遵循标准	ASTM D1003/D1044,ISO 13468/ISO14782,JIS K 7105,JIS K 7361,JIS K 7136,GB/T 2410-08
测量参数	ASTM和ISO双标准下的雾度、透射率
光谱响应	CIE光谱函数Y/V ()
光路结构	0/d
测量口径	21mm
量程	0-100%
分辨率	0.01%
重复性	0.08
样品大小	厚度 145mm
显示	5英寸TFT液晶屏
存储数据	20000个数值
接口	USB接口
电源	DC12V/3A
工作温度	5~40 ，相对湿度80%或更低（在35 下），无水气凝结
储藏温度	-20 ~45 ，相对湿度80%或更低（在35 下），无水气凝结
体积	长X宽X高：310mmX215mmX540mm
重量	6kg
标配	PC管理软件（Haze QC）
选配	测量夹具、雾度标准片、定制口径板

外观结构介绍

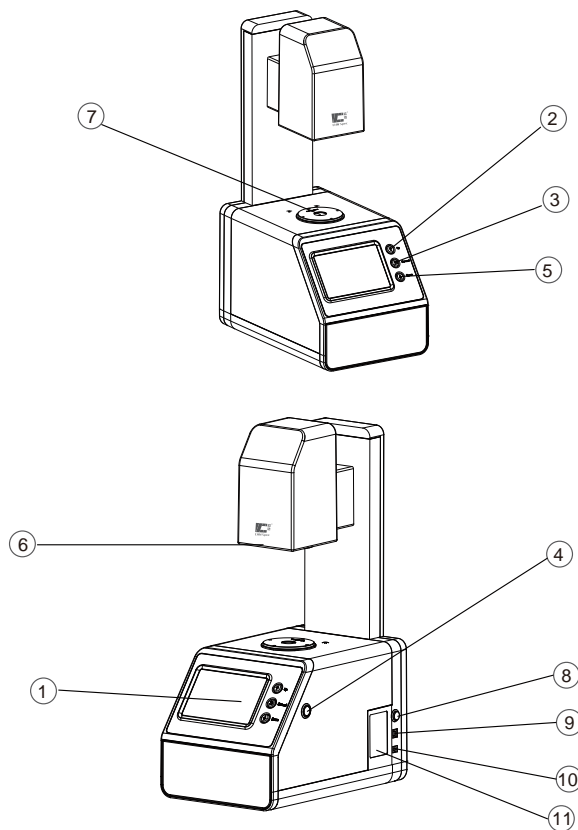

- | | | |
|---------|---------|---------|
| ① 显示屏 | ⑤ 向下选择键 | ⑨ USB接口 |
| ② 向上选择键 | ⑥ 出光口 | ⑩ 电源接口 |
| ③ 返回键 | ⑦ 测试口 | ⑪ 铭牌 |
| ④ 测试键 | ⑧ 电源开关 | |

测量流程图

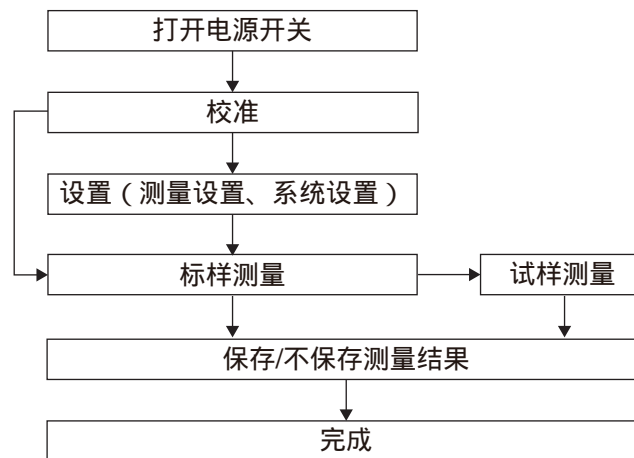

程序界面介绍



A-1

标题栏：显示当前页面主要的功能信息，包括当前时间等信息。

工作区：显示页面下属于菜单的主要功能。

程序基本操作方法：

通过“Up”、“Down”选择键，选择“相应的功能按钮”，“Test”键进入“选择的
功能界面”进行相应操作，“Cancel”键返回上一步骤。

测量：用户可以测量样品的全透雾度和雾度参数，测量试样与标样之间的差异以及查看
所保存的测试记录等。

数据查看：在该页面中用户可以查看已保存的标样下的各项参数，并可对选择的样品进
行查看试样、删除和编辑名称操作。

设置：用户可以对仪器测量条件的各项参数进行选择和设置。

USB通信：用户可以通过USB接口与PC机连接进行数据传输，以及进行上位机操作。

测量

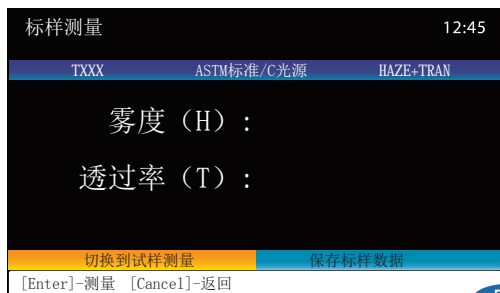

B-1

B-1

标样测量

标样放置完成后，按机器的“Enter”键，“嘀”声后完成测量，查看测量结果。测试
结果的标题栏中，分别显示了标样名称和测试结果的测试标准和参数。当标样未保存时，
标样名称一律显示为“Txxx”，当按“保存”按钮保存标样后，名称显示为保存之后的
标样名。测试标准和参数可在测量前在“测量设置”中进行设置（参考设置章节说明）。

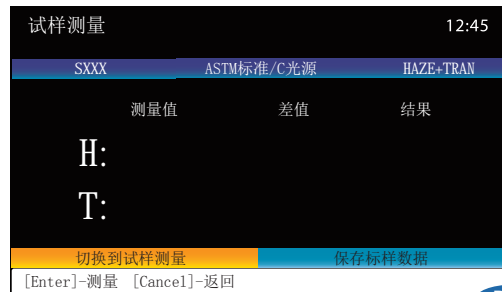

B-2

B-2

试样测量

在上面的标样测量完成并保存后，按“测试样”按钮，即可进入该标样下的“试样测量”
界面，按“Enter”键进行测量，“滴”声后完成试样测量，查看测量结果。再次按下“
测试”键可进行新的试样测量。与标样测量相同，试样测量在未保存时，在测量结果的
标题栏中，第一列名称中的试样名称显示为“Sxxx”，保存后则显示为保存后的名称。

在“数据查看”界面下，同样可以进行试样测量。通过“Up”、“Down”键选择已有
的标样，按“Enter”键进入查看所选的标样。然后在“查看标样”页面下，按
“Enter”键，进入该标样下的试样查看界面，按“Enter”键，调入该试样进入试样测
量界面，按“Enter”键进行测量。“滴”声后完成试样测量，查看测试结果。再次按
下“Enter”键进行新的试样测量。

注：试样测量前请先设置容差。（参看容差设置）

数据查看

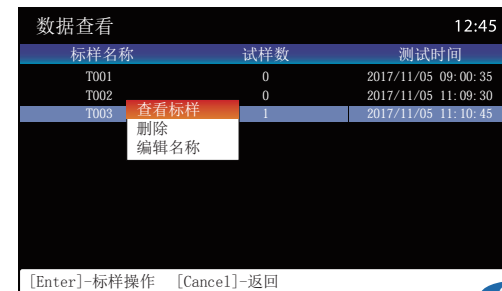

C-1

C-1

通过“Up”、“Down”选择键选择所需查看的标样，按“Test”键，即可弹出菜单窗口，通过“Up”、“Down”选择键，进行查看标样、删除、编辑名称等操作。

查看标样：查看该标样的测试数据。

删除：将删除该标样下的所有试样测试记录。

编辑名称：编辑更改所选标样的名称。



C-2

C-2

通过“Up”、“Down”选择键选择所需查看的试样，按“Enter”键，即可弹出菜单窗口，通过“Up”、“Down”选择键，进行调入试样、删除、编辑名称等操作。

调入试样：查看该试样的测试数据。

删除：将删除该试样下的所有试样测试记录。

编辑名称：编辑更改所选样品的名称。

设置



D-1

D-1

测量设置：在该页面下，用户可以对仪器测量中的光源、容差、测量平均数、测试标准、测试参数等选项进行设置。

系统设置：在该页面下，用户可以对语言、时间、电源管理进行设置，以及对仪器进行恢复出厂设置，查看本仪器的版本号信息。

校准：在该页面下，用户可以对仪器进行校准操作。

测量设置



E-1

E-1

通过“Up”、“Down”选择键选择，按“Test”键进入“测量设置”页面。

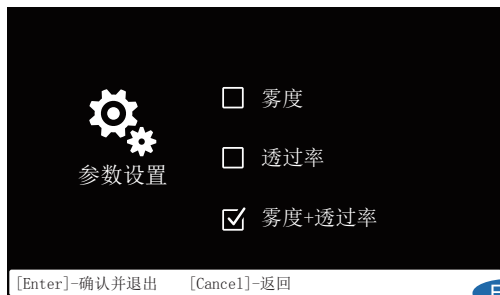

E-2

E-2

参数设置：通过“Up”、“Down”选择键选择“显示设置”，按“Enter”键进入显示设置页面。按“Up”、“Down”键，选择您需要显示的测量参数，按“Enter”键确认。当您选择某一项后，测量页面将显示您所选的内容。



E-3

E-3

光源选择：通过“Up”、“Down”选择键选择“光源选择”，按“Enter”键进入光源设置页面。本页面下可以选择在测量页面显示任一种光源下的测量数据，通过“Up”、“Down”选择键进行选择，按“Enter”键确认。

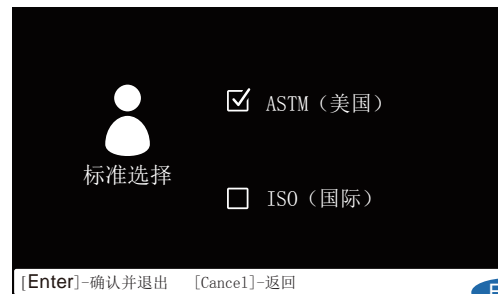

E-4

E-4

标准选择：通过“Up”、“Down”选择键选择“标准选择”，按“Enter”键进入标准选择页面。按“Up”、“Down”键，选择您需要测试标准，按“Enter”键确认。当您选择某一项后，在进行测试时会按照您选择的标准进行。标准进行切换之后需要重新进行校准。



E-5

E-5

测量模式：通过“Up”、“Down”键选择“测量模式”，按“Enter”键进入测量模式页面。在本页面下通过“Up”、“Down”键选择“快速模式”或“高精度模式”。快速模式下，透过率显示精度为0.1，雾度<10时，雾度显示精度0.01，雾度 10时，雾度显示精度0.1；高精度模式下，透过率和雾度显示精度均为0.01。

系统设置

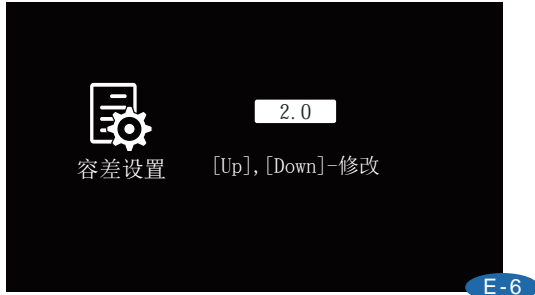

E-6

容差设置：通过“Up”、“Down”键选择“容差设置”，按“Enter”键进入容差设置页面。在本页面下通过“Up”、“Down”键修改数值，按“Enter”键确认。



E-7

平均设置：通过“Up”、“Down”键选择“平均设置”，按“Enter”键进入平均设置页面。在本页面下通过“Up”、“Down”键修改数值，按“Enter”键确认。



F-1

通过“Up”、“Down”选择键选择，按“Enter”键进入该“系统设置”页面。“系统设置”页面中可进行：语言设置、时间设置、电源管理、恢复出厂、查看版本等操作。



F-2

语言选择：通过“Up”、“Down”选择键选择“语言选择”，按“Enter”键进入语言设置页面。本仪器提供中文、英文两种界面语言，通过“Up”、“Down”键选择，按“Enter”键确认。

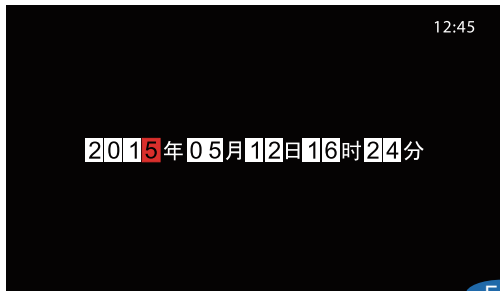

F-3

F-3

时间设置：通过“Up”、“Down”选择键选择“时间设置”，按“Enter”键进入时间设置页面。设置修改本仪器的测量显示时间，可对年、月、日、时、分进行设置，“Up”、“Down”键选择修改项，“Test”键确认，再按“Up”、“Down”键修改数值，按“Cancel”键选择保存、退出。

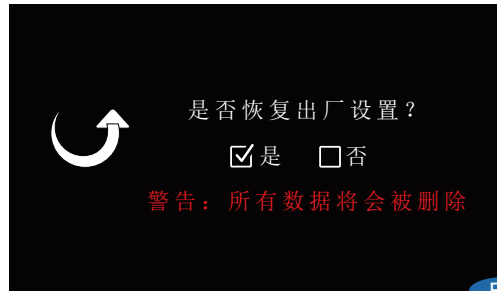

F-5

F-5

恢复出厂：通过“Up”、“Down”选择键选择“恢复出厂”，按“Enter”键进入恢复出厂页面。恢复出厂后，所有的数据将会被删除，并且设置系统将会恢复到默认设置。



F-4

F-4

电源管理：通过“Up”、“Down”选择键选择“电源管理”，按“Enter”键进入电源管理页面。可对仪器的背光时间进行修改设置。“Up”、“Down”键选择修改项，“Enter”键确认，再按“Up”、“Down”键修改数值，按“Cancel”键选择保存、退出。

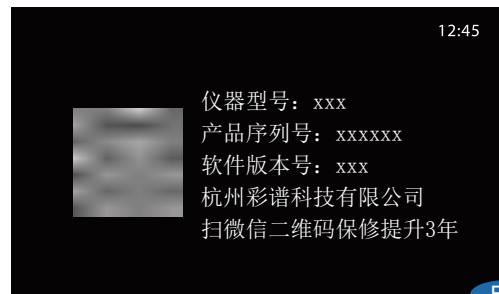

F-6

F-6

版本：通过Up、Down选择键选择“版本”，按“Enter”键进入“版本查看”页面。显示本仪器的版本号信息，包括仪器型号、产品序列号、软件版本号。

校准



G-1

根据仪器界面提示，保持测试口对准空气，按下仪器右侧侧面的按钮进行校准操作。



H-2

当USB线插入USB接口，正常连接时如上图显示。

USB通信



H-1

在主页面，通过“Up”、“Down”选择键，选择“USB通信”图标，按“Enter”键，进入“USB通信”页面。当USB线未插入USB接口或USB线与USB接口接触不良时，将如图显示。插入USB接口或重新插入即可正常连接，进行上位机操作。

参数介绍

雾度

漫散射会降低物体的成像质量。材料内部细小的颗粒或样品表面会引起散射，散射光会散射到不同的角度且每个角度的光密度都很小，这会导致对比度的降低，样品会形成如牛奶或云雾状的外观，这一现象称为雾度。根据ASTM D1003标准，雾度是超出2.5° 散射的透射光所在全部透射光的百分比。

透明度评估条件

透明产品外观具有光泽、颜色和透明度等特性。透明度尤为重要，其评估条件为：透光率，雾度等。透过率是全部透射的光与入射光的比率。它会随材料表面对光的反射和吸收而降低。

异常处理分析

异常情况	分析	处理方法
1、仪器无法开机	电源连接可能异常	检查电源接口处是否接触良好，并插好电源
2、开机后不能进入主程序	开机校准过程可能异常	重新按照要求进行校准保证校准顺利通过
3、测量结果报错	容差设置可能异常	检查容差设置并调整
4、测试数值异常	1、样品与测量口贴合紧密与否 2、样品表面损伤是否较大	1、检查样品与测量口的贴合情况，保证紧密贴合 2、检查样品表面情况，保证样品是完好的对测量没有影响的

附件

标配件

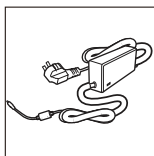

外部电源适配器

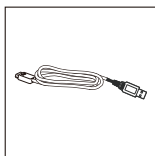

USB数据线

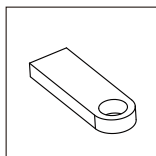

数据管理软件U盘

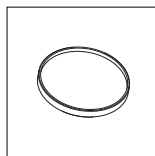

防尘盖

选配件

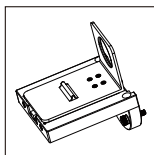

比色皿夹具

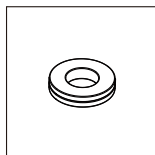

薄膜夹具

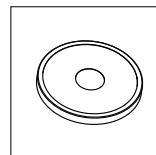

标准片

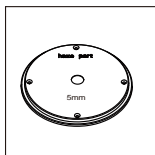

5mm口径板

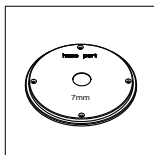

7mm口径板

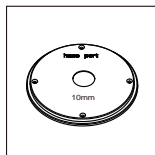

10mm口径板

公司声明

本公司向用户承诺，我们生产的雾度计，保修期限为购买之日起的三年时间内有效，正常使用情况下非人为造成的故障问题，本公司将负责给予免费维修，超过保修期或人为因素导致的故障，本公司将提供维护，将收取维修材料及相关费用。本公司对于第三者因使用本产品引起的任何损失或索赔不负任何责任。本公司对由于因故障、维修或断电造成的数据丢失而导致的任何损害或损失均不负任何责任。为防止重要数据的丢失，请务必对所有重要数据进行备份。本产品中预置的所有作品之版权归本公司所有，受《中华人民共和国著作权法》保护。我公司出售本产品的行为不代表向用户转让或授予与作品版权相关的任何权利。本说明书所提到的产品规格及信息仅供参考，内容会随时更新，恕不另行通知。



China's leading expert of color
and gloss analysis



Haze Meter OPERATION MANUAL ▶ TH-100

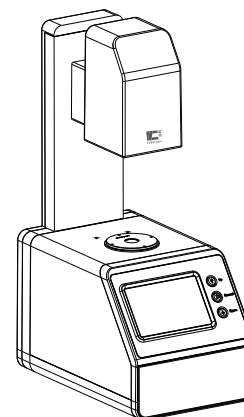

Service hotline:+86 571 85888707

Address:No.166,Wenyuan North Road,Jiangan District,Hangzhou City,China



Please do not disassemble the product without the assistance of customer support center, If you have any questions, please contact the local agency.

www.chnspec.com

CATALOGUE

[I]Haze Meter Term of Use	01
[II]Haze Meter Note	01
[III]Haze Meter Function	02
[IV]Haze Meter Technical Data	02
[V]Appearance and Structure	03
[VI]Measurement Flow Chart	04
[VII]Interface Introduction	05
[VIII]Measurement	05
8.1 Target Measurement	06
8.2 Sample Measurement	06
[IX]Data view	07
[X]Settings	08
10.1 Measurement Setup	08
10.2 System Setup	12
10.3 Calibration	15
[XI]USB	15
[XII]Parameter introduction	16
[XIII]Trouble Shooting	17
[XIV]Accessories	17
[XV]Company's Statement	18

Haze Meter Terms of use

- 1.Haze meter is designed for plastic, films, glass, LCD panel, touch screen and other transparent and semi-transparent materials haze and transmittance measurement.
2. Haze meter can be widely used in labs, factories or worksites, it can meet haze measurement requirement for all industries.
3. Warranty time is one year from the purchasing date. If your instrument need after-sales service, please bring it to local distributor or contact us on website: www.chnspec.com
- 4.To avoid damage on instrument accuracy or precision, please do not disassemble the instrument. Damage to the instrument caused by disassembly or improper use is not included in the warranty.

Haze Meter Notes

- 1.Dropping or collision is dangerous for this precision instrument . please put it on the relatively flat place to start your measurement.
- 2.Moisture or liquid splashing will damage the instrument. It is not damp proof.
- 3.Large force, or sharp objects may easily damage the glass screen .
- 4.Please use our original adapter if possible.
- 5.Do not use or store it in too hot or cold environment, neither wet nor sunlight shining places. Dangerous to use it under strong vibration. Please take care and avoid accidents.
6. Keep it away from strong magnetisms. It interfere the precision instrument.
- 7.Please keep the instrument steady; do not shake the instrument in usage
- 8.Please shut down the instrument after using
- 9.Please store the instrument in a dry place
- 10.You are not permitted to clean the interior of integrating sphere.
- 11.Please contact us if the instrument get a problem, don` t try to fix it yourself.
- 12.This instrument and its instructions are subject to further improvement or supplement without prior notice.

Haze Meter functions

1. Haze meter conforms to standards: GB/T 2410, ASTM D 1003, ISO 13468 , ISO 14782 and GB/T 2410-2008.
2. Haze meter can provide haze and transmittance value under CIE-A, CIE-C and CIE-D65 light sources.
3. Haze meter contains compensation method which provides higher accuracy on test result.
4. Open sample measurement area to make it can measure samples at any sizes.
5. Haze meter adopts 5.0 inch TFT display screen for friendly interface.
6. Haze and transmittance analysis software to meet customer's different requirement on data analysis and management.

Haze Meter Technical Data

Light Source	CIE-A 、 CIE-C 、 CIE-D65
Standard	ASTM D1003/D1044,ISO 13468/ISO14782,JIS K 7105,JIS K 7361,JIS K 7136,GB/T 2410-08
Measurement parameter	ASTM and ISO (HAZE),Transmittance (T)
Spectral Response	CIE Luminosity function Y/V (λ)
Geometry	0/d
Measuring caliber	21mm
Measurement Range	0-100%
Resolution	0.01%
Repeatability	0.08
Sample Size	Thickness \leq 145mm
Screen	5 inch TFT LCD screen
Memory	20000 values
Interface	USB
Power	DC12V/3A
Working Temperature	5~40 , Relative humidity 80% or lower (35) no condensation

Storage Temperature	-20 ~ -45 , Relative humidity 80% or lower (35) no condensation
Size	LxWxH: 310mmX215mmX540mm
Weight	6kg
Standard Accessory	PC management software(Haze QC)
Optional	Measurement Fixture, Haze Standard, Customize caliber board

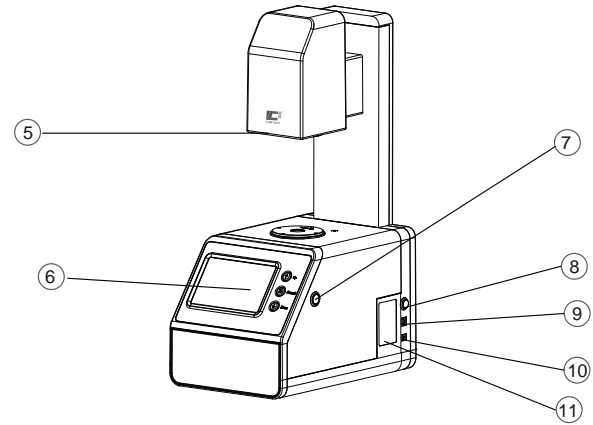

Appearance and structure

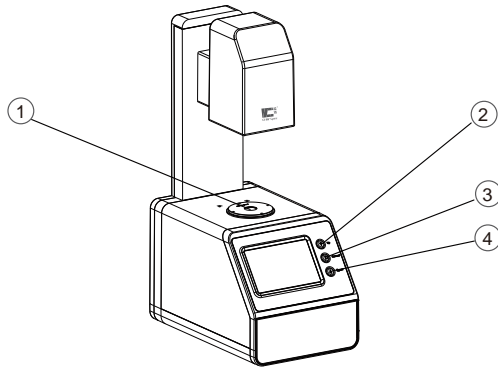

Measurement flow chart

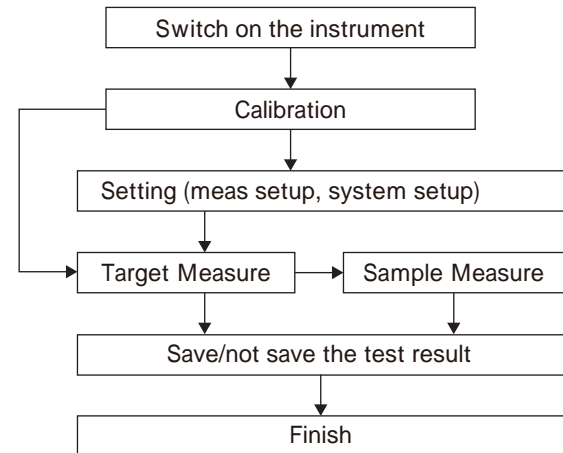

- | | | |
|-----------------|-----------------------|-------------------|
| ① Test Aperture | ⑤ Light Exit Aperture | ⑨ USB |
| ② UP | ⑥ Display Screen | ⑩ Power Interface |
| ③ CANCEL | ⑦ TEST | ⑪ Nameplate |
| ④ DOWN | ⑧ Switch on - off | |

Interface Introduction

A-1

Main interface

① Title: Show the page function including time and standard.

② Working Area: Show the main function of submenu.

③ Condition area: display current conditions of the current page

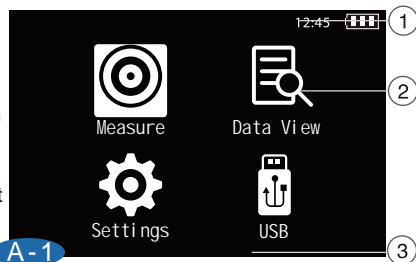

Operation:

Press “up” or “down” to choose the function, press “Test” to confirm your choice. Press “cancel” will go back to previous step.

Measure:

We can measure haze and transmittance. Compare the difference between target and sample. Save the test value.

Data View:

We can view the saved target value, sample value under the target, edit the sample name and delete the sample.

Setting :

We can set measurement parameters.

USB:

We can connect instrument with PC for data transfer and measure on PC.

Measurement

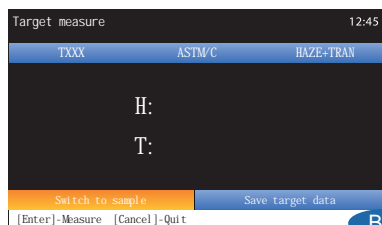

B-1

Standard Sample Measurement

After the standard sample is placed, press the “Enter” button of the machine, After measurement, the test result can be seen on the instrument screen. Separately displaying the standard sample name and the standard and parameters of the test result in the title bar of the measurement results. When the standard sample is not saved, the name of the standard sample is always displayed as “Txxx”. When the standard sample is saved by pressing the “Save” button, the name appears the saved standard sample name. Test standard and parameters can be set in the setting interface before. .measurementmeasurement. (Refer to the setup chapter description)

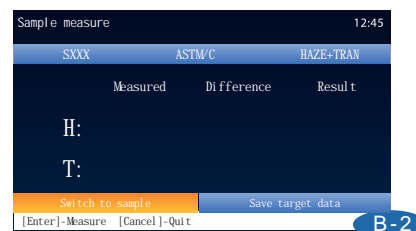

B-2

Sample Measurement

After the standard sample measurement is completed and saved, press the “Enter” button to enter the “Sample Measurement” interface under the standard sample, press the “Enter” button to measure, after the measurement is finished, we can see the test result on screen. Press the “Enter” button again to make a new sample test result. As with the standard measurement, when the sample measurement is not saved, the name of the sample is always displayed as “Sxxx”. When the sample test result is saved by pressing the “Save” button, the name appears the saved sample name.

Data View

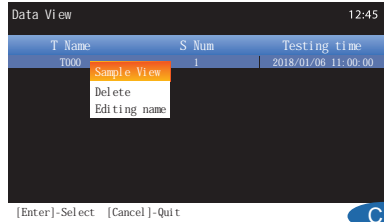

C-1

C-1

Press the “Up” or “Down” buttons to select the standard sample you want to view. Press “Enter” button, the menu window will pop up. Press the “Up” or “Down” button to check the standard sample. Delete, Edit Name, etc.
View the standard sample: View test data for this standard.
Delete: All sample test records under this standard sample will be deleted.
Edit Name: Edit the name of the selected standard sample.

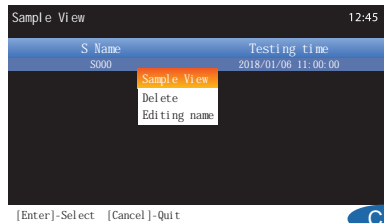

C-2

C-2

Press the “Up” or “Down” buttons to select the sample you want to view. Press “Enter” button, the menu window will pop up. Press the “Up” or “Down” button to transfer into the sample. Delete, Edit Name, etc.
Transfer into the sample: View test data for this standard.
Delete: All sample test records under this sample will be deleted.
Edit Name: Edit the name of the selected sample.

Settings

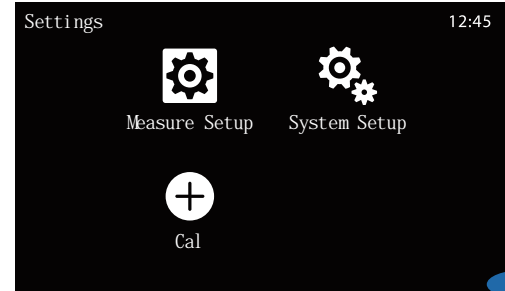

D-1

D-1

Measurement Settings: User can set parameter, light source, reference, tolerance and average.
System Settings: User can set language, time, power, reset all and version.
Cal: User can do calibration for haze meter.

Measure Setup

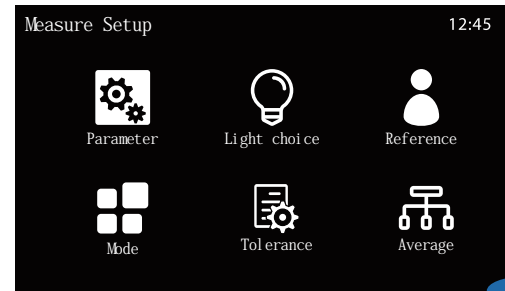

E-1

E-1

Press the "Up" and "Down" button to select and press "Enter" button to enter the "Measurement Settings" interface.

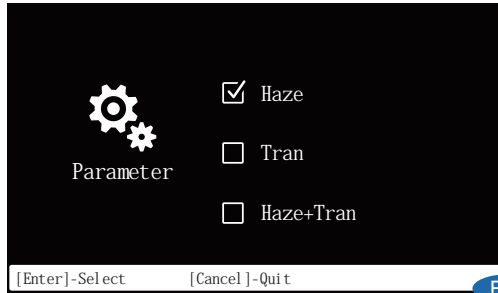

E-2

E-2

Press "up" or "down" to select parameter, and press "Enter" to enter the setting page. Press "up" or "down" to select parameter you need, press "Enter" to confirm the choice.

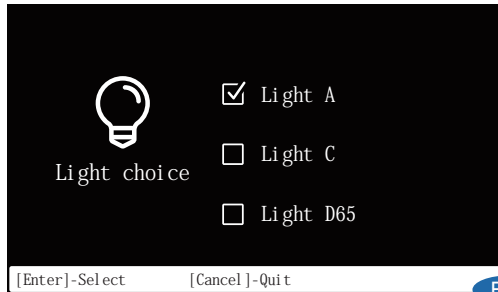

E-3

E-3

Light Choice: Choose Light choice by pressing "up" or "down". User can select the measurement data under any light source on the measurement page by pressing "Enter". User can select the light source by pressing "up" or "down",press "Enter" to confirm your choice.

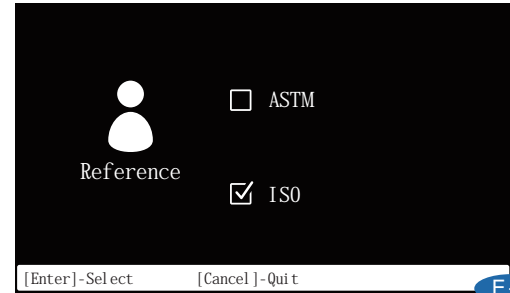

E-4

E-4

Reference:Choose reference by pressing "up" or "down", press "Enter" to confirm. User can select the measurement standards ASTM or ISO. When you select the standard, the test is performed according to the standard. Calibration is required after the standard is changed.

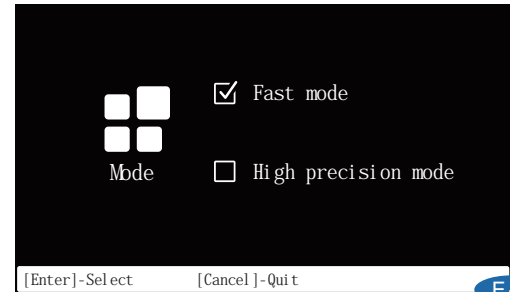

E-5

E-5

Mode:Choose reference by pressing "up" or "down", press "Enter" to confirm. User can select "Fast mode" or "High precision mode". Fast mode means when haze < 10%, Resolution is 0.01, when haze ≥ 10%, Resolution is 0.1, but the resolution of Transmittance is 0.1. High precision mode means the Resolution of Haze and Transmittance is 0.1.



E-6

E-6

Tolerance: Choose Tolerance by "Up" and "Down", press "Enter" to confirm. User can modify the value by pressing "Up" and "Down" and press "Enter" to confirm.

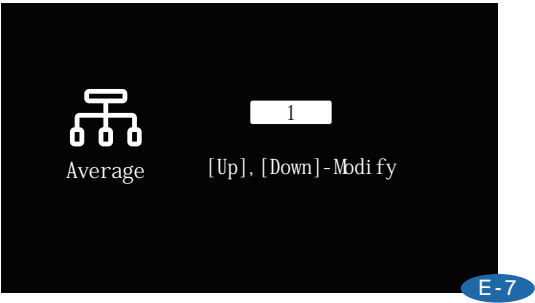

E-7

E-7

Average: Choose average by pressing "up" or "down", press "Enter" to confirm. User can modify the average value by press "up" or "down", press "Test" to confirm it.

System Setup

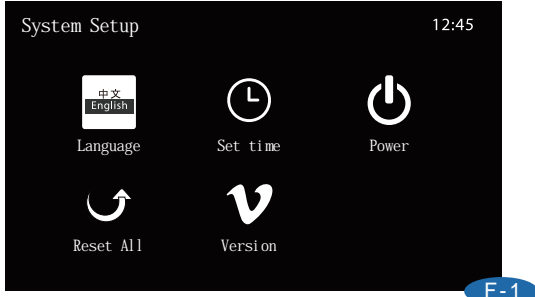

F-1

F-1

Press "up" or "down" to select the system setup, press "Enter" to enter into the system setup page. User can set language, time, power, reset all and view instrument version.

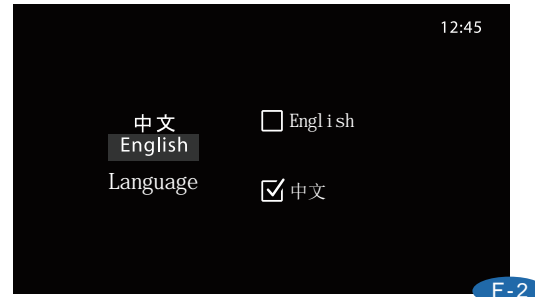

F-2

F-2

Language: Instrument support two languages English and Chinese. User can choose language by pressing "up" or "down", press "Enter" to confirm.

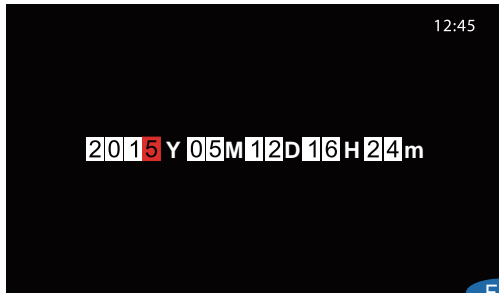

F-3

F-3

Time setting: User can set the instrument time such as year, month, date, hour and minute. Press "up" or "down" we can change the value, press "cancel", we can choose save or exit.

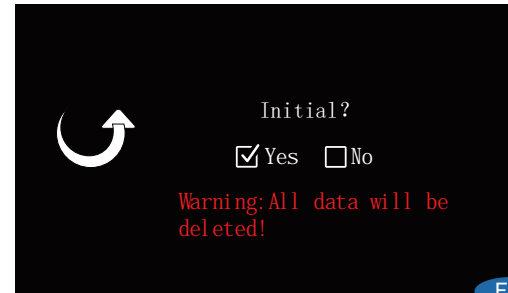

F-5

F-5

Reset all: If user do reset all, all saved data will be deleted and setting will revert to default settings.

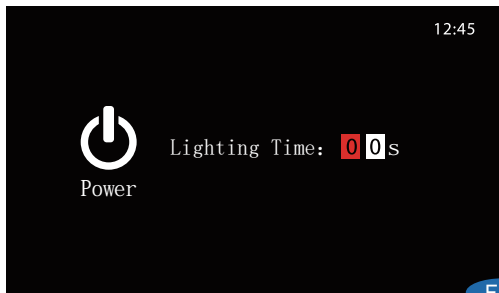

F-4

F-4

Power: User can set the instrument lighting time. Press "up" or "down", we can setting the lighting time. Press "cancel" to save or exit.

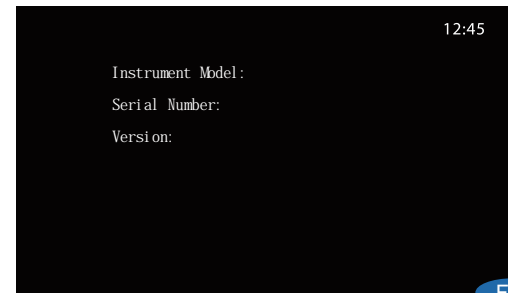

F-6

F-6

Version: User can see instrument mode, serial number and instrument version.

Calibration



G-1

Keep the haze-port open ,then press the side button for calibration.

USB



H-1

On the main page, select USB by press "up" or "down", press "Enter" to enter into USB page. When the USB cable is not plugged or not well contact with USB interface,above figure will show on instrument. Plug the USB cable or reconnect with the USB interface



H-2

When the USB cable access to the USB interface, the normal connection as shown above.

Parameter introduction

Haze

Diffuse scattering reduces the image quality of the object. Small particles inside the material or sample surfaces cause scattering, and scattered light is scattered to different angles and the optical density at each angle is small. It causes a decrease in contrast and the sample forms a milky or cloud-like appearance, this phenomenon is known as haze.

Conditions for the assessment of transparency

Transparent product appearance has the characteristics of gloss, color and transparency. Transparency is particularly important, and its evaluation conditions are: transmittance, haze and so on. The ratio of light to incident light when the transparency rate is all projected. It will decrease as the surface of the material reflects and absorbs light. According to the ASTM D1003 the percentage of light that when passing through that deviates from the incident beam by greater than 2.5 degrees on average is defined as haze.

Trouble Shooting

Trouble Shooting	Analysis	How to solve?
1.1.Instrument does not power on	Power connection may be abnormal	Check the Power interface for good contact and plug in the power supply
2.No access to main interface after start	The power-on calibration process may be abnormal	Re-calibrate as required
3.Error in measurement results	Tolerance settings may be abnormal	Check tolerance settings and adjust
4.Test result is not correct	1.The sample is close to the test port or not 2.Whether the sample surface is with scratches	1.Check the sample and test port fit to ensure close fitting 2.Check the sample surface condition to ensure that the sample is at good condition and has no effect on the measurement

Accessories

Standard Accessories

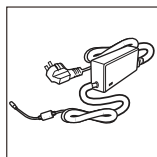

Power Adapter

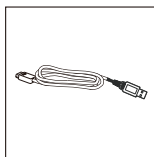

USB Cable

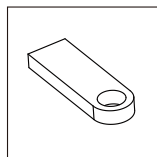

Software U disk

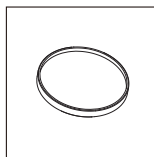

Dust cover

Optional Accessories

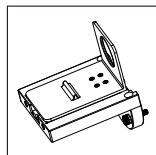

Cuvette Fixture

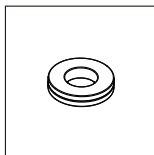

Film Fixture

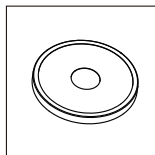

Haze Standard

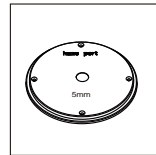

5mm Aperture

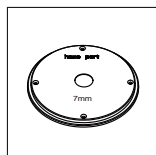

7mm Aperture

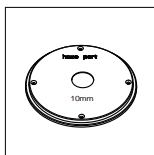

10mm Aperture

Company statement

- 1.Our company commits to our customers 1 year warranty period for our Haze Meter from the date of the purchase, and our company shall be responsible to provide free maintenance for non-human caused malfunctions under normal usage. For malfunctions that are out of warranty period or caused by human factors, the company shall provide maintenance, and materials and repair shall be chargeable.
- 2.The company is not liable for any loss or claim arising from the use of this product by the third party.
- 3.The company is not liable for any damage caused by loss of data due to failure, maintenance or power off. To prevent the loss of the data, be sure to back up all your data.
- 4.The copyright of all products belongs to the company and is protected by copyright law of the People's Republic of China.
- 5.Our company's sale of this product does not represent the transfer or grant of any rights related to the copyright of the works to the user.
- 6.The product specifications and information mentioned in this specification are for reference only and will be updated at any time without prior notice.